

UNIT: mm (毫米)

HBAN

红波

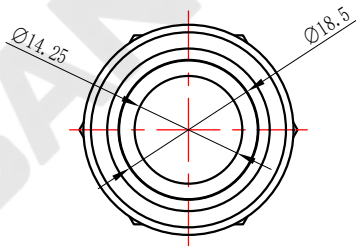
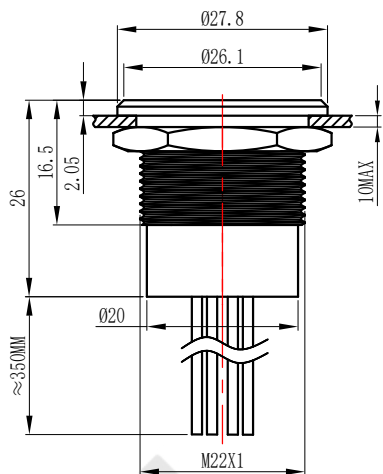
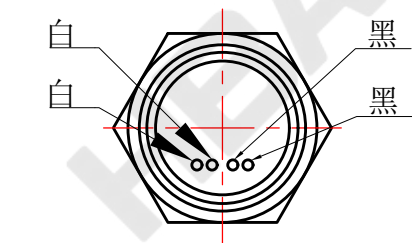

开关结构说明: Switch structure description:

电源输入:
(Power input):
6-24V AC/DC



安装孔尺寸: Mounting hole size:

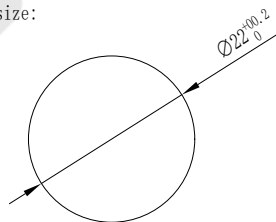

性能要求:

Performance requirements:

1. 防护等级: IP68、IK09;
Protection grade: IP68、IK09
2. 接触电阻: $\leq 100\text{m}\Omega$;
Contact resistance: $\leq 100\text{m}\Omega$;
3. 脉冲时间: $\leq 50\text{ms}$;
Pulse time: $\leq 50\text{ms}$;
4. 寿命: 电气部分在额定负载下动作100万次无异常。
Life: electrical part: operate 1000000 times under rated load without any abnormality.

技术要求:

Technical requirements:

1. 表面光洁, 平整无毛刺;
The surface is smooth and smooth without burr;
2. 参数/批次字迹清晰, 无错位;
Clear handwriting of parameters/batches without any dislocation;
3. 电气参数: $I_{th}: 500\text{mA}$ $U_i: 6-24\text{V/DCAC}$;
Electric parameter: 500mA $U_i: 6-24\text{V/DCAC}$;
4. 工作温度: $-40^\circ\text{C} \sim +70^\circ\text{C}$;
Working environment temperature: $-40^\circ\text{C} \sim +70^\circ\text{C}$;
5. 动作形式: 脉冲; 自锁式; 自复式;
Action form: Pulse; Momentary; Latching;
6. 动作行程: 无;
Movement stroke: There is no;
7. 连接形式: 焊接导线;
Connection form: welding wire;
8. 拧紧力矩: 约0.6Nm;
Tightening torque: about 0.6Nm;
9. 开关组合: 1NO;
Switch combination: 1NO;
10. 操作压力: 5-10N
Operating pressure: 5-10N
11. 外观材料: 按键: 不锈钢; 铝合金;
Appearance material: Keypad: stainless steel; Alum
12. 未标注公差按照GB/T 1804-m级。
Unmarked tolerance shall be in accordance with GB/T 1804-m class.
13. 灯珠参数: 额定电压: 6V/12V/24V/36V; 110V/220V;
额定电流: $\leq 20\text{mA}$;
Lamp bead parameters: Rated Voltage: 6V/12V/24V/36V; 110V/220V;
Rated current: $\leq 20\text{mA}$
14. 灯珠颜色: 红/绿;
Lamp color: red/green;
15. 灯珠寿命: 50000小时。
Led life: 50000 hours.

描 图

描 校

底 图 号

装 订 号

					SHANGHAI HONGBO ELECTRIC CO. LTD.	
					上海红波电器有限公司	
标记	处数	更改文件号	签字	日期	名称(TITLE): M22 Metal electronic switch	
制图	APPD. 审核	SCALE. 比例	countersign. 会签	date. 日期	M22金属电子开关	
鲁靖坤	李振方	1.5:1		2024.10.8	图号(DWG NO): HBPS22C-10EZ/Y/S/204	
单重		页码	第1页 共1页(1/1)			